

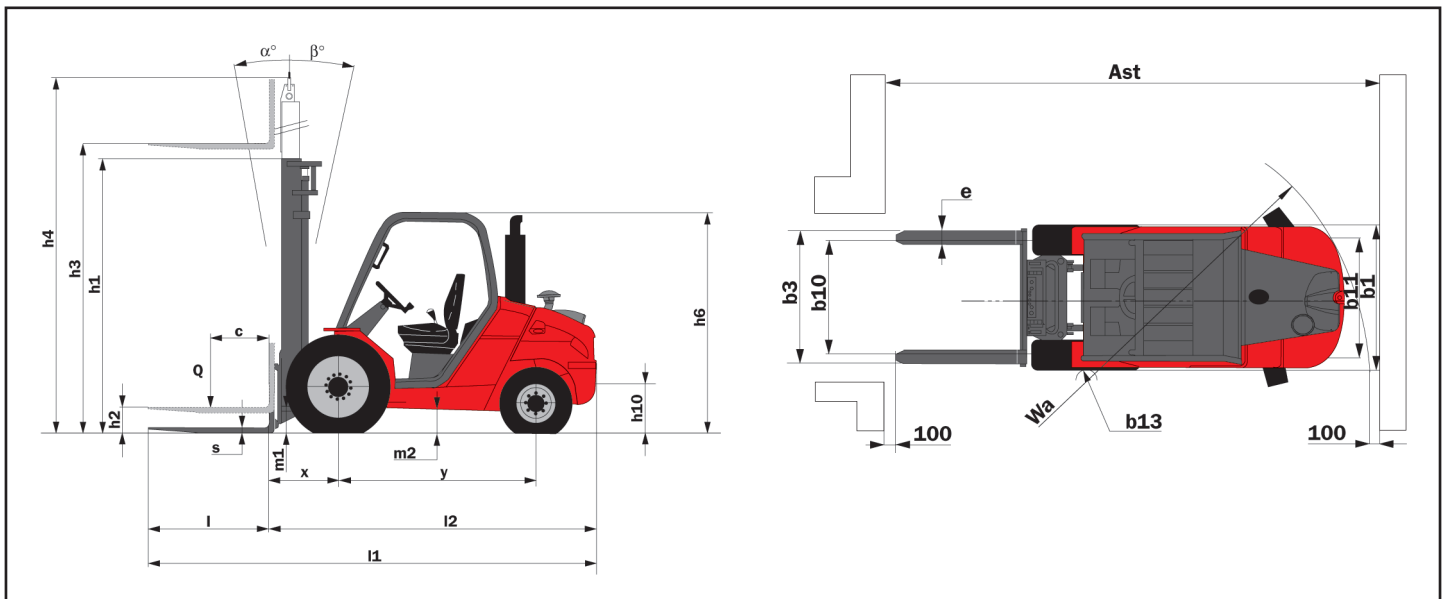

 **MANITOU**

				MANITOU	MANITOU
				MH 20	MH 25
		Q		2000	2500
		c		500	500
		x		625	625
		y		1800	1800
				4050	4350
				5091 / 864	5812 / 948
				1841 / 2114	1750 / 2510
				280/80 R20 XMCL	280/80 R20 XMCL
				27,10 - 12 IC 30 14PR	27,10 - 12 IC 30 14PR
				4	4
		b10		1450	1450
		b11		1160	1160
		α / β		10 / 12	10 / 12
		h1		1835	1835
		h2		-	-
		h3		3300	3300
		h4		4070	4070
		h6		1990	1990
		h7		1025	1025
		h10		470	470
		l1		4045	4045
		l2		2945	2945
		b1		1450	150
		s / e / l		40 / 100 / 1100	40 / 100 / 1100
		b3		1260	1260
		m1		270	270
		m2		260	260
		Ast		5090	5090
		Ast		5290	5290
		Wa		2500	2500
		b13		1080	1080
				14 / 14	14 / 14
				0,4 / 0,6	0,6 / 0,6
				0,6 / 0,5	0,6 / 0,5
				3550 / 2190	3550 / 2190
				57 / 52	50 / 48
				44	44
				1600	1600
				4/2434	4/2434
				125	125
				77	77
				81	81



MH 2,0 & 2,5 T			DVT27	DVT30	DVT33	DVT35	DVT37	DVT40	DVT45
			h3*	mm	2730	3030	3330	3530	3730
h1	mm	1995	2145	2295	2395	2555	2745	2995	
h2	mm	130	130	130	130	130	130	130	
h4	mm	3531	3831	4131	4331	4531	4831	5331	
MH20	kg	2000	2000	2000	1800	1600	1500	1100	
MH25	kg	2500	2500	2500	1900	1900	1550	1100	

MH 2,0 & 2,5 T			DLL30	DLL33	DLL35	DLL37	DLL40	DLL45				
			TLL37	TLL40	TLL43	TLL47						
h3*	mm	3040	3340	3540	3740	4040	4540	3740	4040	4340	4740	
h1	mm	2145	2295	2395	2555	2745	2995	1945	2045	2145	2295	
h2	mm	1388	1538	1638	1798	1988	2238	1216	1316	1416	1566	
h4	mm	3797	4097	4297	4497	4797	5297	4469	4769	5069	5469	
MH20	kg	2000	2000	1800	1600	1500	1100	1600	1500	1200	1000	
MH25	kg	2500	2500	1900	1900	1550	1100	1900	1550	1250	1000	

NASH

PLANT GROUP

Sales & Hire

1 3 0 0 6 2 7 4 7 4



 **MANITOU**