

# ICARUS

DIECI ICARUS TELEHANDLER 4 T / 16.6 M



40.17

**DIECI**  
AUSTRALIA

## PERFORMANCE

Machine model	ICARUS 40.17
Maximum capacity	4000 kg (8818 lb)
Maximum lifting height on stabilisers	16.60 m (54.5 ft)
Maximum horizontal extension on stabilisers	12.80 m (42 ft)
Fork swiveling angle	134°
Pull-out force	5700 daN (12814 lbf)
Towing force	7300 daN (16411 lbf)
Maximum climb angle	40%
Unladen weight	12260 kg (27029 lb)
Max speed (referred to wheels with maximum permitted diameter)	35 km/h (21.7 mph)

## BOOM

Machine model	ICARUS 40.17
Lifting	14.1 s
Getting off the basket	10.2 s
Extension	21.4 s
Retraction	14.1 s
Forward swiveling	3.3 s
Reverse swiveling	2.1 s

## ENGINE

Machine model	ICARUS 40.17
Brand	FPT
Nominal power	93 kW (125 HP)
@rpm	2200 rpm
Operation	4-stroke
Injection	Mechanical direct
Number and arrangement of cylinders	4, Vertical in line
Displacement	4485 cm <sup>3</sup> (274 in <sup>3</sup> )
Consumption	230 g/kWh (378.35 lb/Hp h)
@rpm	2200 rpm
Emission standards	Stage IIIA/Tier 3
Cooling system	Liquid
Intake	Turbo compressor after-cooler

## DIFFERENTIAL AXLES

Machine model	ICARUS 40.17
Axles types	2 steering, with 4 planetary reduction gears
Type of steering	4 wheels / transversal / 2 wheels
Front axle	Rigid (Leveling upon request)
Rear axle	Swinging
Service brake	Oil bath with servo brake on front and rear axle with double hydraulic system
Park brake	Automatic spring applied hydraulic release

## HYDRAULIC SYSTEM

Machine model	ICARUS 40.17
Hydraulic pump type	Gear pump for power steering and movements
Hydraulic pump capacity	130 L/min (34.3 gal/min)
Max. operating pressure	25.0 MPa (3626 psi)
Distributor control	4in1 proportional Joystick

## REFUELING

Machine model	ICARUS 40.17
Hydraulic motor (total)	174.0 L (45.97 gal)
Diesel tank	105.0 L (27.74 gal)

## TRANSMISSION

Machine model	ICARUS 40.17
Transmission type	Hydrostatic with variable flow pump
Hydraulic motor	Hydrostatic with continuous automatic adjustment
Reversal	Electro-Hydraulic
Inching	With hydraulic pedal for controlled forward movement
Transmission gearbox	Servocontrolled 2-speed

## TYRES

Machine model	ICARUS 40.17
Standard tyres	18x22.5"

# DIMENSIONS

Machine model	ICARUS 40.17
A	390 mm (15.4 in)
B	1970 mm (77.6 in)
C	2950 mm (116.1 in)
D	1355 mm (53.3 in)
F	4900 mm (192.9 in)
G	6275 mm (247 in)
H	2550 mm (100.4 in)
I	940 mm (37 in)
L	1950 mm (76.8 in)
M	2360 mm (92.9 in)
N	3270 mm (128.7 in)
O	4900 mm (173.2 in)
P	1700 mm (66.9 in)
Q	4400 mm (173.2 in)
S	1837 mm (72.3 in)
T	163 mm (6.4 in)

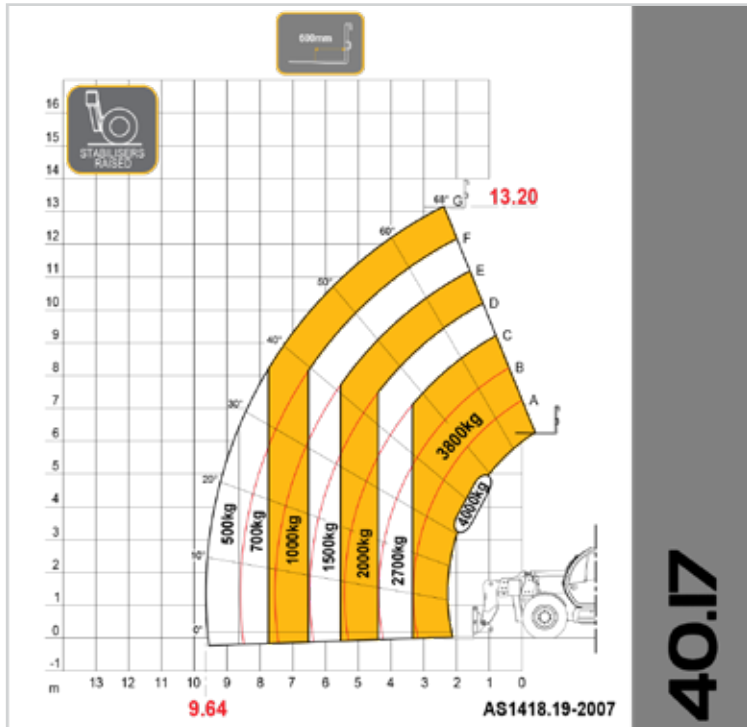
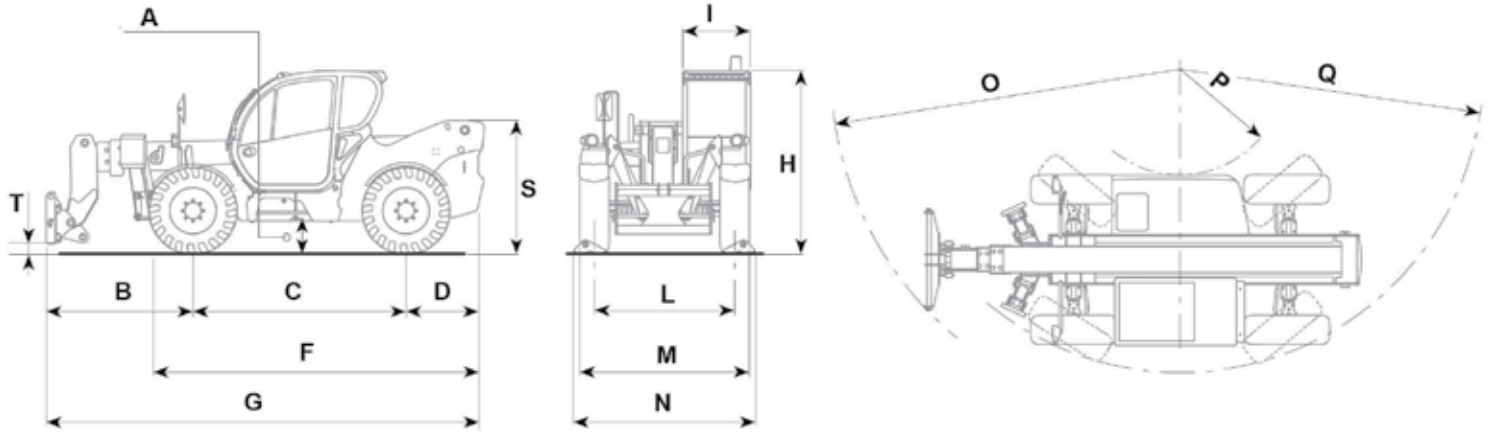

40.17

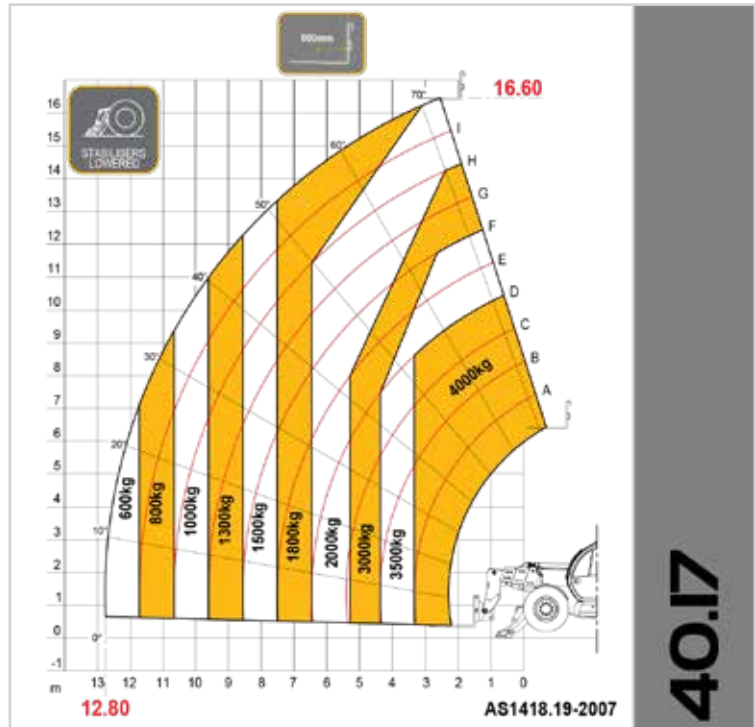

40.17



Distributed by Dieci Australia and their network of authorised dealers.

25 Garner Place, Ingleburn NSW 2565  
[www.dieciaustralia.com.au](http://www.dieciaustralia.com.au) | [info@dieciaustralia.com.au](mailto:info@dieciaustralia.com.au)  
Tel. +61 2 8795 4555

Illustrations and photos show the standard international models and may or may not include optional equipment, accessories, customer installed or modified parts, optional parts and all standard equipment with some differences in colour and features. Machine specifications are subject to change without notice and additional load charts and machine or attachment specifications may be available on request. Please refer to the operators manual for correct machine and attachment operation.

Printed in Australia SKT Icarus EXTRA-EC-AU | 1.6 2019

