

Dingli 
Australia

www.dingliaustralia.com.au



Raptor

MV095J

SELF-PROPELLED MAST LIFT

Raptor

MV095J

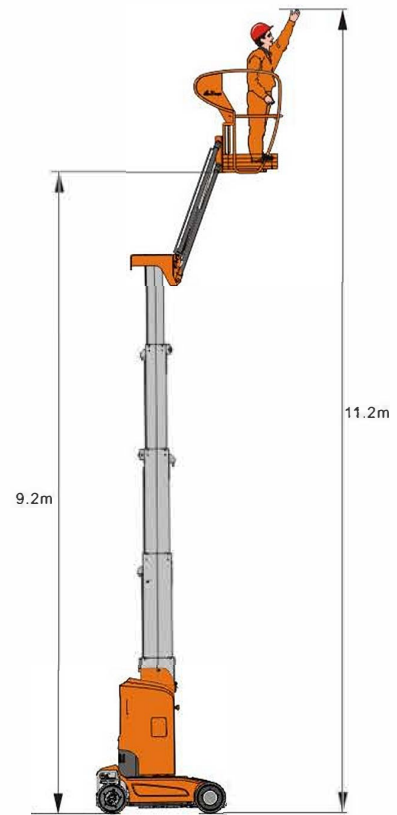
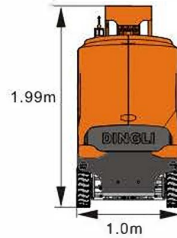
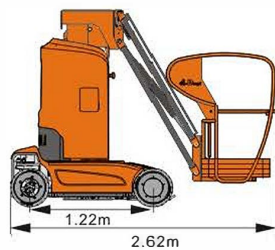

	S.W.L	200kg/441lb
	Max.occupants	2
	Working height	11.20m/36ft9in
	Platform floor height	9.20m/30ft2in
	Horizontal outreach	3.00m/9ft10in
	Up and over height	7.89m/25ft10in
	Overall length	2.62m/8ft7in
	Overall width	1.00m/1ft3in
	Overall height	1.99m/6ft6in
	Platform size	0.62x0.87m/2ft0.4inx2ft10in
	Ground clearance(Stowed)	0.075m/3in
	Ground clearance(Raised)	1.019m/3ft4in
	Wheelbase	1.22m/4ft
	Turning radius	1.80m/5ft11in
	Turret rotation	345°
	Jib movement	+70°/-60°
	Drive motors	24V/1.5kw
	Lifting motors	24V/3kw
	Travel speed(Stowed)	4.5km/h 2.8miles/h
	Travel speed(Raised)	0.5km/h 0.3miles/h
	Up/Down speed	95/50 sec
	Batteries	24V/240Ah
	Integrated charger	24V/30A

	Gradeability	25%
	Maximum slope	2.5°
	Tyres	φ 381x127mm
	Weight	2950kg/6503lb

Standard Equipment

- Proportional Controls
- Automatic Pothole Protection
- Self Close Gate On Platform
- Drivable At Full Height
- Platform Horizontal Outreach
- Non-marking Tyres
- 2WD
- Automatic Brake System
- Emergency Lowering System
- Emergency Stop Button
- Cylinder Holding Valve
- Onboard Diagnostic System
- Tilt Sensor With Alarm

- All Motion Alarm
- Horn
- Hour Meter
- Charger Protection
- Flashing Beacon
- Swing Out Components Cover
- 345° Turret Rotation
- Overload Sensor With Alarm

Options

- AC Power To Platform
- Platform Work Lights
- Airline To Platform



1 3 0 0 6 2 7 4 7 4

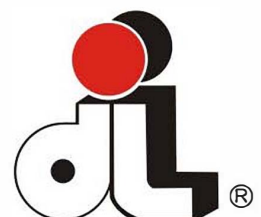

Please Note:-
All information contained in this publication was correct at time of printing but may be subject to change without notice.