

# ELECTRIC SCISSOR LIFTS

## Compact 8 / 10N\*



### OPTIMUM COMPACTNESS

- > Width of 81 cm to operate in the most congested areas
- > Compact stowed height for easy access through standard doorways

### EXCEPTIONAL PRODUCTIVITY

- > Load capacity up to 350 kg (C 8)
- > Driveable at full height
- > Extended platform
- > Long working cycles

### RELIABLE, EASY TO MAINTAIN

# **nash**

**PLANT GROUP**

*Sales & Hire*

1 3 0 0 6 2 7 4 7 4

\*Compact 10N: indoor only

# Compact 8 / 10N

## ELECTRIC SCISSOR LIFTS

### TECHNICAL DATA

	COMPACT 8	COMPACT 10N
Working height	8.2 m	10 m
Platform height	6.2 m	8 m
Maximum drive height	6.2 m	8 m
Lift capacity - inside	350 kg (2 pers.)	230 kg (2 pers.)
Lift capacity - outside	120 kg (1 pers.)	N/A
Lift capacity on the extension deck	120 kg	120 kg
<b>A</b> Platform length - outside	2.31 m	2.31 m
<b>B</b> Platform length - extended	3.23 m	3.23 m
Length - extension	0.92 m	0.92 m
<b>C</b> Platform width - outside	0.81 m	0.81 m
<b>E</b> Storage height	1.13 m	1.32 m
<b>D</b> Height - stowed	2 m	2.18 m
<b>F</b> Overall width	0.81 m	0.81 m
<b>G</b> Length	2.49 m	2.49 m
<b>H</b> Wheelbase	1.86 m	1.86 m
<b>I</b> Ground clearance - center	13 cm	13 cm
Ground clearance - deployed potholes	2.5 cm	2.5 cm
Drive speed	1 - 3.3 km/h	1 - 3.2 km/h
Gradeability	23 %	23 %
Tilt	2 °	2 °
Turning radius - outside	2.38 m	2.38 m
Non-marking tyres	15 x 5	15 x 5
Batteries	24 V - 225 Ah (C20)	24 V - 225 Ah (C20)
Hydraulic system capacity	27 l	27 l
Weight	1 655 kg	2 190 kg

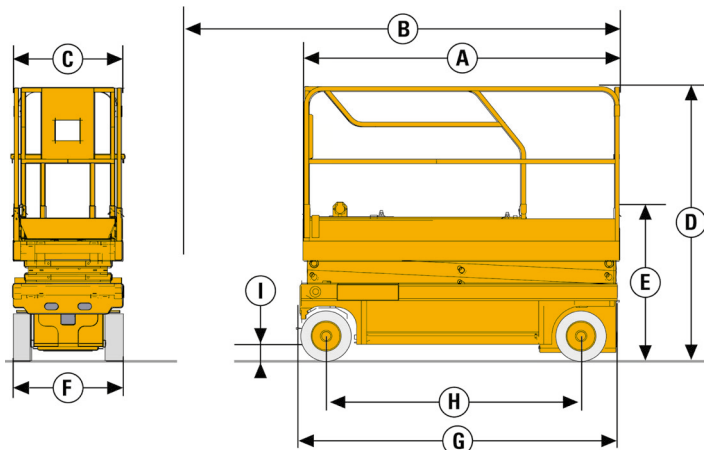

### STANDARD EQUIPMENT

- > Pothole guards
- > Battery charge indicator
- > Proportional lift and drive
- > Folding handrails (C 10N)
- > Swing out component tray
- > Battery charger with automatic stop
- > Solid non-marking tyres
- > Free wheeling device
- > Tilt controller
- > Load Management System in the platform
- > Manual platform lowering valve
- > Integrated forklift pockets
- > Towing hooks
- > Horn
- > Hourmeter

### OPTIONS AND ACCESSORIES

- > Flashing light (standard in AU / NZ)
- > Travel alarm (standard in AU / NZ)
- > Working light
- > Power to platform
- > Biodegradable hydraulic oil
- > Folding guardrails (C 8)
- > Centralised battery filling

