

# HA26 RTJ PRO



## PERFORMANCE & PRODUCTIVITY

- > Very good working envelope
- > Vertical arm rise - basket remains parallel to wall
- > Outstanding RT capabilities
- > Large modular basket
- > Dual load basket capacity 250 - 350 kg

## SAFETY AND COMFORT

- > Quick, proportional and simultaneous movements
- > Haulotte Activ'Lighting System safe load
- > Haulotte Activ'Shield Bar 2.0

## MINIMIZED TOTAL COST OF OWNERSHIP

- > Haulotte Activ'Screen (on board diagnostic)
- > Haulotte Stop Emission System automatically turns the engine off & on
- > Easy access to all components
- > Large modular basket, quick and easy to repair

**nash**

PLANT GROUP

*Sales & Hire*

1 3 0 0 6 2 7 4 7 4

# HA26 RTJ PRO

## ROUGH TERRAIN ARTICULATING BOOMS

### TECHNICAL DATA

#### HA26 RTJ PRO

Working height	26.4 m
Platform height	24.4 m
Horizontal outreach	17.5 m
Up and over clearance	9.3 m
Lift capacity	250 kg (2 pers.) - option 350 kg
<b>F</b> x <b>G</b> Platform size	2.44 x 0.91 m
<b>A</b> Length - stowed	11.8 m
<b>B</b> Width	2.48 m
<b>C</b> Height - stowed	2.97 m
<b>H</b> Storage / transport length	9.4 m
Storage / transport height	2.98 m
Platform rotation	180 °
Vertical jib rotation	133° (- 65° / + 68°)
Turntable rotation	360° continuous
Tailswing	0.76 m
<b>D</b> Wheelbase	2.8 m
Ground clearance	48 cm
Tilt	4 °
Drive speed	5 km/h
Maximum wind speed rating	45 km/h
Gradeability	45 %
Turning radius - outside	4.35 m
Tyres - solid rough terrain	1025 x 365 mm
Power source	Kubota, 36.5 kW (49.6 hp), Stage 3A
Weight	15 500 kg

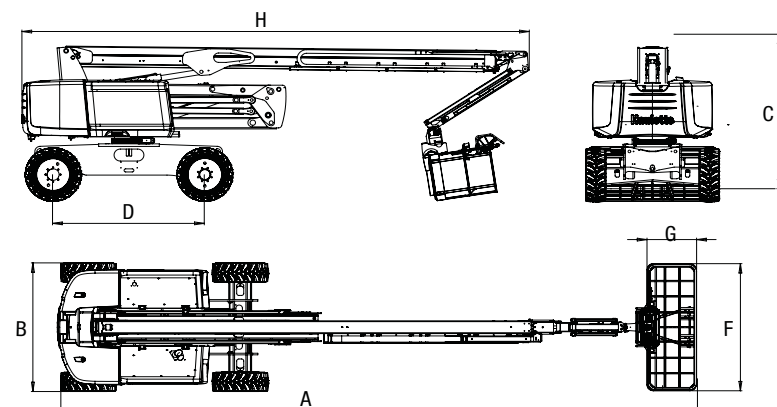

### STANDARD EQUIPMENT

- > Haulotte Activ'Screen: embedded diagnostic system on lower control box, with color screen
- > Haulotte Activ'Shield Bar 2.0
- > Haulotte Activ'Lighting System, safe load
- > Haulotte Stop Emission System: automatic engine stop system
- > Universal telematics plug
- > 4 wheel drive, 4 wheel steer
- > Front oscillating axle
- > 4 simultaneous movements
- > Automatic differential wheel lock
- > Upper control box cover
- > Tool tray
- > Large modular Haulotte basket 2.44 m x 0.91m
- > Lateral swing door entry gate
- > AC power to platform (110 / 230 V)
- > Swing out engine tray
- > Sound and light alarm for tilt and load
- > Rotating beacon
- > Travel alarm
- > Electric pump system and emergency descent
- > 12 V battery / electrical control system
- > Engine pre-heater with light indicator
- > Low fuel level indicator (upper control box), fuel gauge (lower control box)

### OPTIONS AND ACCESSORIES

- > Non marking tyres (standard in AUS / NZ)
- > Dual load capacity 250 / 350 kg (restricted) (standard in AUS / NZ)
- > 60 km/h wind speed
- > Power to platform (female plug in the basket)
- > Air-line to platform
- > Drop bar entry gate
- > Hydraulic generator 6.5 kVA (standard in AUS / NZ)
- > Biodegradable hydraulic oil
- > Hydraulic oil cooler
- > Cold weather kit - 20° / arctic weather kit - 25°C
- > Pipe cradle pack
- > Glazier pack
- > Working light
- > Battery circuit breaker

