

P25.6 - XG

# PANORAMIC P 25.6

PROVISIONAL DATASHEET



**MERLO**

*BUILDING WITH CONFIDENCE.*



# CONCENTRATED FORCE

## A TINY PACKAGE FULL OF POWER



### UNCOMPROMISED PERFORMANCE

The innovative Panoramic P 25.6 telescopic handler is the result of exciting technological development. It's compact, strong and safe, and it offers the ideal solution for working in confined spaces, where conventional telescopic handlers just cannot reach.

The concept of a compact telehandler was first invented by Merlo back in 1991, with the revolutionary P 20.6. Thanks to a unique concept and its unbeatable performance, it was the sector benchmark for many years.

Now, the introduction of the P 25.6 sets new standards, confirming Merlo once again as the technological leader in this sector of compact telehandlers. Our engineers and designers focussed upon safety and size, resulting in the production of a machine that is tiny in dimensions (only 1.80 metres wide and less than 2 metres tall), reliable and quick, but is able to handle up to 2.5 tonnes or lift to a height of six-metres. As with all Merlo telehandlers, the driver is absolutely not forgotten. Although of diminutive dimensions, the P 25.6 has the same cab as its premium-range brothers - a cab that's 995 mm wide, with plenty of space, several storage compartments, and incredible panoramic visibility.

**COMFORT**

The cab is the same size as the premium-range models, offering the same great **visibility**, the same **comfort**, and the same **safety**.

**COMPACT**

One of the obvious features of this new telehandler is its **very compact size**, both **in width** - just 1.80 metres - and **in height** (less than 2 metres).

**SPEED**

The excellent off-road performance of these new telehandlers and their **maximum speed of 36 kph** gets them all around the site very quickly.

**MANOEUVRABILITY**

No telehandler has ever been so manoeuvrable and easy to handle with just a light grip on the steering wheel. This P25.6 also offers unrivalled **accuracy and agility** for material handling.

**POWER**

The **turbo diesel engine** delivers **up to 55 kW (75 HP)**, impressive power for this class, which allows Merlo's new baby to meet the needs of a variety of applications with a wide range of attachments.



# WINNING INNOVATION

DESIGN, COMFORT, PERFORMANCE



## THE COMPACT TELEHANDLER ACCORDING TO MERLO!

Innovative design and engineering have produced a particularly robust chassis, creating the greatest strength from its steel heart.

Permanent four-wheel drive, all-wheel steering, extraordinary ground clearance with generous approach and departure angles and road travel at up to 36 kph, all add up to an unrivalled driving experience.

A low centre of gravity and good weight balance assure safe travelling and good stability on all surfaces.

The P 25.6 is an efficient and comfortable working system, giving its best in reliability, quality, profitability and above all, safety!

The telescopic **boom extension mechanism** is housed entirely within the boom assembly, protecting it from site damage and ensuring maximum productivity.

The **cab is the widest available** in this machine class, because it is the same as fitted on larger-sized Merlo models. Its **generous glazed area** offers **real panoramic visibility** of the working area.

The standard **hydraulic quick-attach fork carriage** allows attachments to be quickly interchanged using the controls in the cab. A double-acting hydraulic service fitted with quick couplings provides the power for hydraulically-operated equipment.

The standard **longitudinal stability control system** automatically locks all aggravating movements when the machine is reaching the limit of its forward stability.

The **epicyclic reduction axles** are designed and manufactured by Merlo, exclusively for this telescopic handler application.



# THE CAB

## FIRST CLASS FOR SAFETY AND VISIBILITY



### THE SAME CAB BIGGER MERLO TELEHANDLERS

Safety and driver comfort are the guiding priorities for Merlo, and they have heavily influenced the cab design and engineering.

The cab frame is compliant with international ISO 3449 (FOPS) and ISO 3447 (ROPS) standards on falling object and rollover protection, and it is fixed upon special elastic mounts, designed to reduce vibration and increase the driver's comfort. For the same reasons, mechanical and hydraulic control assemblies are placed directly on the chassis, with all main services controlled electrically.

The cab features the widest interior space in its market. An exceptionally deep windscreen and wide rear window - both openable - ensure excellent visibility of the working area. Superb upwards visibility is provided by the wide shock-resistant roof glazing.





◀◀  
The telescopic boom is controlled with a **proportional hydraulic joystick** with On/Off switches (photo left). An **electro-proportional joystick** is available as an option (photo below).



◀  
The cab is easy to enter with self-cleaning steps and a flat, obstacle-free floor. Both upper and lower sections of the cab door open through a full 180°.



◀  
There is an **analogue instrument panel**, with a **digital display** showing the main operating parameters.



▶  
A column-mounted **electrical Finger-Touch control** allows the driver to reverse driving direction without taking his hands off the steering wheel.



▲  
An optional **two-position sunscreen** ensures comfort, even in bright sunlight.

# THE TELESCOPIC BOOM

## MUSCLES OF STEEL



### ONE HAND CAN LIFTING 2.5 TONNES

The telescopic boom is the core of every telehandler. It must be robust and strong - to ensure a good load capacity and safe extension. But it must also be rigid, even at its maximum extension, so as to prevent undue flexing and the 'banana boom' effect. Merlo engineers have created a telescopic boom design that has become a legend in the industry.

The boom sections are made of two U-shaped high-strength steel plates, longitudinally welded to each other along or close to their neutral axis. The hydraulic extension mechanism is fully enclosed within the boom sections and protected from site damage. The boom sections slide on special adjustable anti-friction pads, made of new-generation polymers, exclusively used by Merlo.



From an operating point of view, the new P 25.6 is characterised by its performance and versatility.

With an **almost endless list of attachments** and optional equipment, which can be interchanged on the fork carriage (photo 1) in only a few moments, this telehandler is immediately operational in a variety of different activities.

**Equipment hitching and locking** is controlled directly from the cab, with hydraulic quick-couplings making connection of the hydraulic supply simple, making the machine immediately operational (photo 2).

Equipping the fork carriage with the **hydraulic locking Tac-Lock system** (photo 3) gives these telehandlers an

extraordinary competitive advantage against conventional, manual hitching systems.

Optionally, an **electrical outlet** is mounted on the boom upper section for the selection and the powering of a variety of electrically controlled equipment.



1

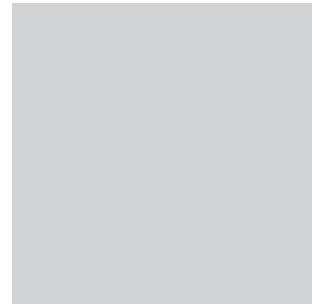

The **boom extension mechanism**, together with its hydraulic and electrical components, is fitted completely within the boom sections, ensuring maximum protection and reliability.



2



3

**MANY MACHINES IN ONE**

Merlo attachments result from integrating their engineering with the base machine design. Designed and produced in-house, and they further widen the tremendous versatility of the new P 25.6. They maximise its potential, enhance its versatility, and suit it for many different market sectors.

- 1 - Carriage-mounted hook
- 2 - Jib
- 3 - Round-bale handler
- 4 - Manure fork with grab
- 5 - 4x1 bucket
- 6 - Multipurpose bucket with grab

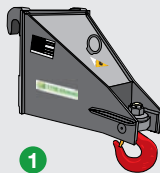

1

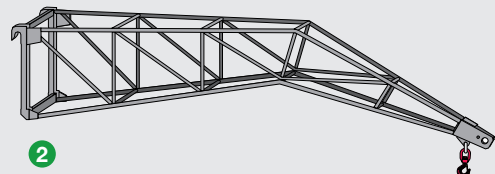

2

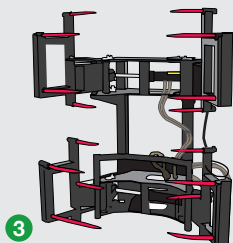

3

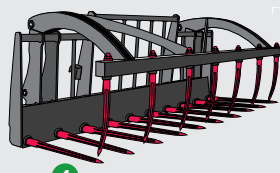

4

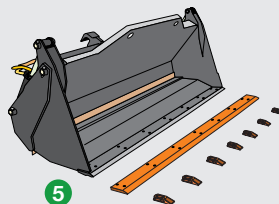

5

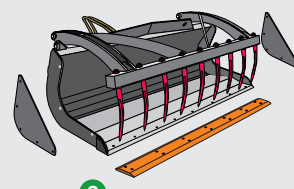

6

# THE ENGINE

## POWER IN ACTION



### **FULL POWER WHENEVER IT'S NEEDED**

These new telehandlers are powered by a Kubota four-cylinder turbo diesel engine, compliant with Tier 3 emission standards, delivering a power of 55 kW (75 HP). Providing ample torque throughout its operating range, it will ensure a prompt response to any power demand.

The engine is mounted low down on the right-hand side of the chassis for greater accessibility and safer servicing. Service engineers can work with their feet resting firmly on the ground, with all mechanical and hydraulic assemblies close at hand.

The transmission is hydrostatic and utilises a variable displacement motor and pump set, delivering high performance and a wide control range at full power. The maximum travel speed is as high as 36 kph.





▶ The **hydrostatic transmission** has a high dynamic braking effect, minimising the need for brakes.



◀ A **high-performance engine**, efficient **hydrostatic transmission**, and **permanent four-wheel drive** ensure great driving performance and safety.

**THE HYDRAULIC SYSTEM**

The hydraulic circuit is powered by a **gear pump**. Hydraulic oil delivery varies according to the engine rpm, controlled directly through the accelerator pedal.

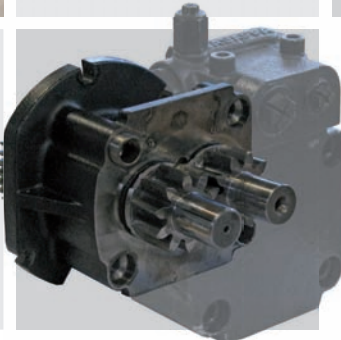

**THE HYDROSTATIC TRANSMISSION**

Oil flow, pressured by a hydraulic pump, is sent to the hydrostatic motor - mounted directly on the rear axle differential - which then turns it into mechanical power. This power is transferred to the axles through a gearbox and a propeller shaft.

The driving speed is infinitely adjustable by pressure applied to the accelerator pedal, without the necessity to change gears as in conventional mechanical transmissions.

The **hydrostatic transmission** is **combined with a permanent four-wheel drive**, ensuring **optimum mobility and control** even in difficult conditions.

The **Inching-Control pedal** allows for minute-distance control while keeping a high engine rpm. This is particularly useful while excavating or stockpiling materials.

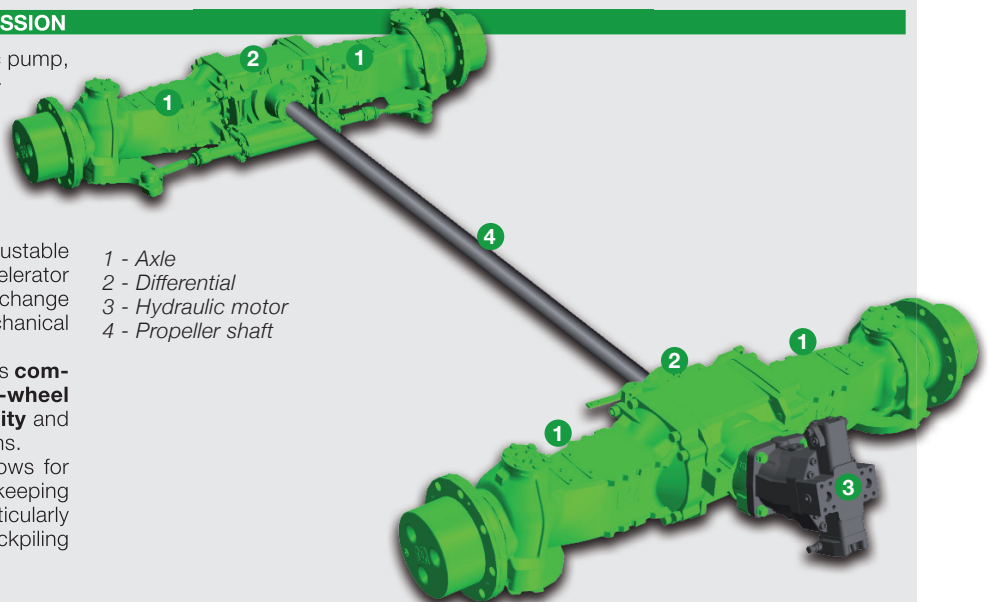

- 1 - Axle
- 2 - Differential
- 3 - Hydraulic motor
- 4 - Propeller shaft

# AXLES

## IMPOSSIBLE TERRAIN? GO FOR IT!



### **STRENGTH AND RELIABILITY ARE BUILT-IN**

Drop portal axles, designed and manufactured in-house by Merlo, increase both driving satisfaction and machine stability on any terrain. Designed for heavy-duty applications, the concept places the main axle body above the centreline of the wheel hub. Compared with traditional axle design, it provides a greater ground clearance with equal-sized tyres.

The rear axle is freely oscillating, adapting to levels even in extreme off-road conditions and ensuring maximum tyre grip, by reducing wheel spin. If necessary, an optional fully-locking rear differential is available.



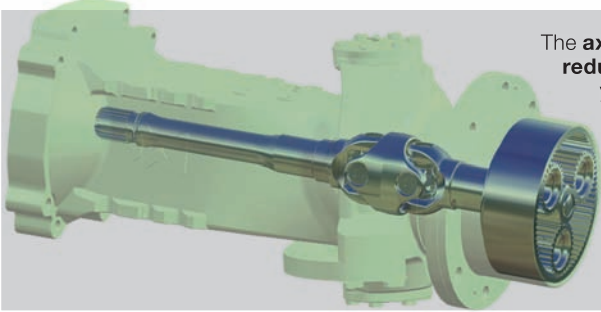

The **axles** are equipped with **epicyclic reduction hubs**. The drive train layout developed by Merlo engineers **reduces both noise and pitch** during braking and acceleration, improving driving comfort and load retention.

**ALL-WHEEL BRAKING**

**Servo-assisted hydraulic service disk brakes, with floating callipers**, are fitted to each hub. A dual-circuit hydraulic layout is utilised to guarantee maximum safety. An **automatic parking brake** is applied when the engine is switched off (or via manual selection of the appropriate switch). An **independent, spring-operated disk brake**, acts upon the main transmission propeller shaft.

Rear axle oscillation enhances **off-road performance** of the machine.

Off-road performance is particularly impressive for its class, due to the **high attack, departure and break-over angles**.

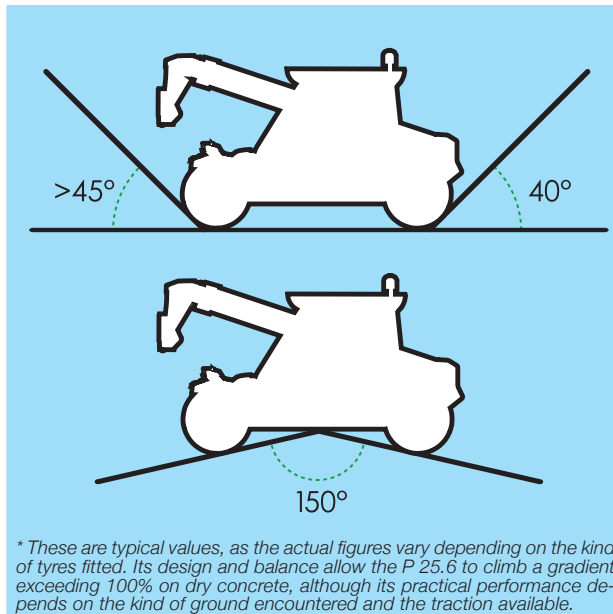

**THREE STEERING MODES**

The four drive wheels are all steered using a hydraulic power steering system. The operator has a choice of three steering modes, with automatic wheel re-synchronisation available in the event of misalignment.

- **Front wheel steer** for road travel (Fig. A);
- **All-wheel steer** to achieve the smallest turning radius (Fig. B);
- **Crab steer** to move the machine sideways without losing longitudinal align-

ment (Fig. C).

When all-wheel steer is selected, the turning radius of this telehandler is smaller than that of an ordinary family car!



# THE VALUE OF TECHNOLOGY

## FACTS AND FIGURES

### UNLEASH THE POWER OF VERSATILITY

Choosing the **new P 25.6** means experiencing every day the advantages offered by cutting-edge technologies, as well as by a safe, reliable and comfortable machine from which you can really demand the most.

- 1 - Loading and stockpiling.
- 2 - Cattle shed and stable cleaning.
- 3 - Heavy-duty handling.
- 4 - Cattle feeding.

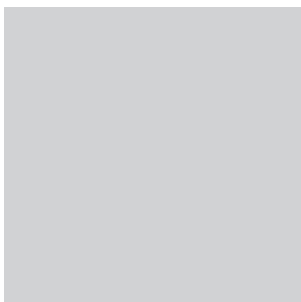
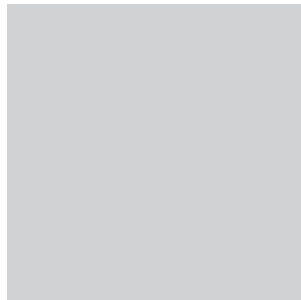



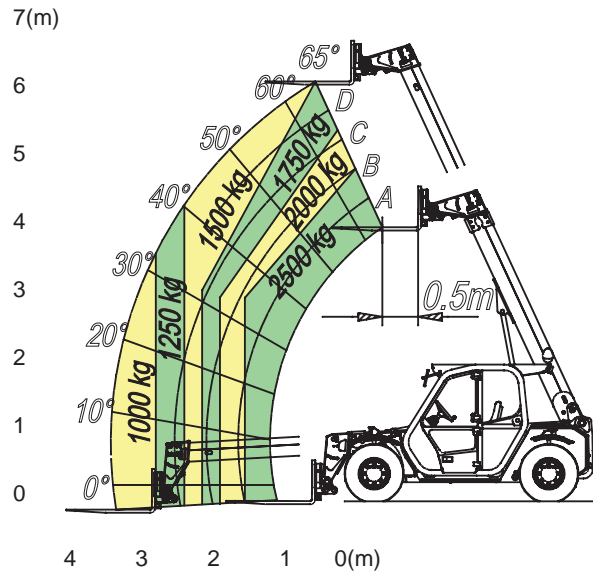
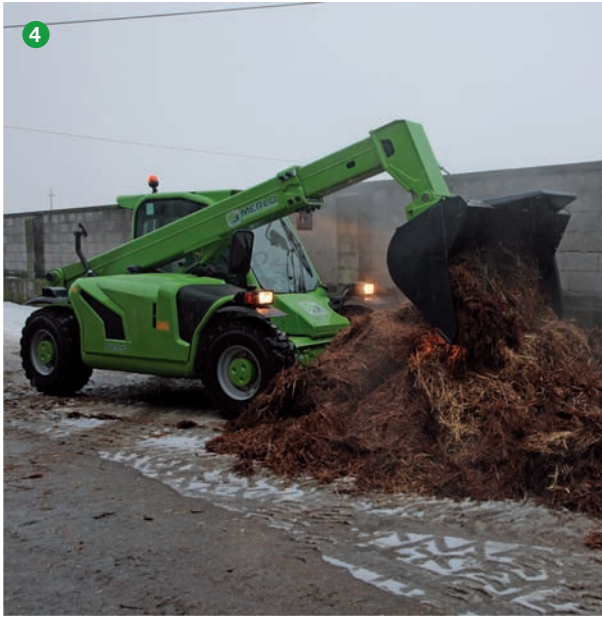

**CHARACTERISTICS AND PERFORMANCE**

Total weight unladen, with forks (kg)	4500
Maximum load capacity (kg)	2500
Maximum lift height (m)	5.9
Maximum forward reach (m)	3.3
Lift height at maximum load capacity (m)	4.7
Forward reach at maximum load capacity (m)	1.4
Load capacity at maximum height (kg)	1,750
Load capacity at maximum forward reach (kg)	1,000
Engine (make/number of cylinders)	Kubota/4
Tier 3 engine power (kW/HP)	55/75
Fuel capacity (l)	70
Maximum speed (kph)	36
Hydraulic system - Gear pump (bar-l/min)	210/80
Hydraulic oil capacity (l)	70
Electrical circuit (V)	12
Battery (Ah)	100
Cab compliant with ROPS/FOPS standards	●
Proportional mechanical joystick controls	●
Electro-mechanical joystick controls	○
Tac-Lock attachment coupling	●
Auxiliary boom hydraulic service	●
Two floating forks (1,200 mm long)	●
Hydrostatic transmission	●
Finger-Touch direction control	●
Inching Control pedal for minute-distance control	●
Permanent four-wheel drive	●
Four wheel steering	●
Service disk brakes on all wheels	●
Automatically locking parking brake	●
12-16.5 tyres	●
12/75-18 tyres	○
Rear differential lock	○
Four cab working lights (2 f. + 2 r.)	○
Manual air conditioning system	○
Roof window wiper	○
12 V electrical outlet on the boom head	○
Manual battery isolator	○
Front and roof sun shade	○
European farm tractor Type Approval	○

**DIMENSIONS (mm)**

<b>A</b> (mm)	3,900
<b>B</b> (mm)	835
<b>C</b> (mm)	2,450
<b>D</b> (mm)	615
<b>E</b> (mm)	3,480
<b>F</b> (mm)	270
<b>H</b> (mm)	1,800
<b>M</b> (mm)	995
<b>P</b> (mm)	1,920
<b>R</b> (mm)	3,370
<b>S</b> (mm)	4,200

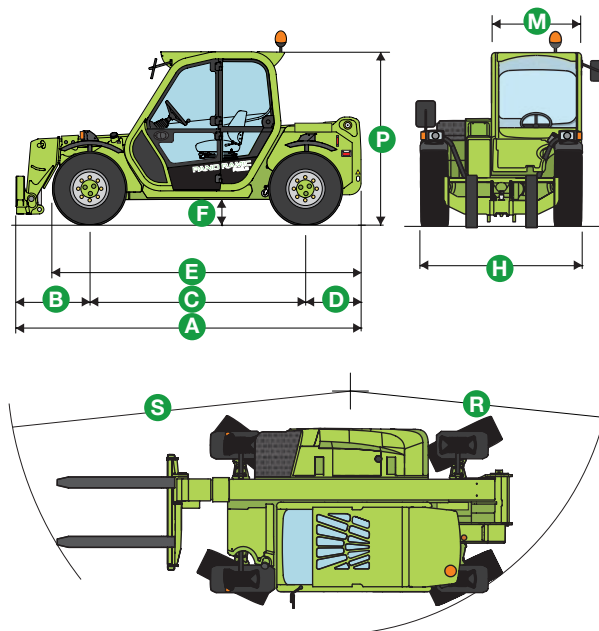

Performance figures refer to the machine equipped with forks.  
 ● Standard. ○ Optional.

The telehandlers featured in this document may feature optional or special equipment which are not part of the standard equipment and are supplied upon request. Not all models or versions are available in all countries, due to regulatory restrictions. Information and technical data are those available at the time of printing. Merlo reserves the right to modify and update the contents of this document at any time without notice, following technological evolution. For further information on our products and services please contact your Merlo dealer.

MKT MERLO • U 416 XG 0310

***nash***  
**PLANT GROUP**  
*Sales & Hire*  
1 3 0 0 6 2 7 4 7 4



**MERLO S.P.A.**

Via Nazionale, 9 - 12010 S. Defendente di Cervasca - Cuneo - Italia

Tel. +39 0171 614111 - Fax +39 0171 684101

[www.merlo.com](http://www.merlo.com) - [info@merlo.com](mailto:info@merlo.com)

