

SPECIFICATIONS

Size	Metric	British
Max. Working Height	30.3m	99ft 5in
Max. Platform Height	28.3m	92ft 1in
Max. Operating Range(+0.6m)	23m	75ft 6in
Max. Platform Range	22.4m	73ft 6in
Overall Length(Stowed) A	12.25m	40ft 2in
Overall Length(Transport)	11.96m	39ft 3in
Overall Width(Stowed) B	2.5m	8ft 2in
Overall Width(Transport)	2.28m	7ft 6in
Overall Height(Stowed) C	2.87m	9ft 5in
Overall Height(Transport)	2.59m	8ft 6in
Platform Size(Length×Width)	2.44m×0.91m	8ft×3ft
Turntable Tailswing	1.61m	5ft 3in
Ground Clearance D	0.41m	1ft 4in
Wheelbase E	2.8m	9ft 2in
Turning Radius(Inside/Outside)	1.87m/3.22m	6ft 2in/10ft 7in
Tyres	385/45-28	385/45-28

Performance		
S.W.L(Unrestricted/Restricted)	300kg/454kg	661lb/1000lb
Max. Occupants	3	3
Gradeability	45%	45%
Travel Speed(Stowed)	6km/h	6km/h
Travel Speed(Raised)	1.1km/h	1.1km/h
Max. Working Slope	X-5°/Y-5°	X-5°/Y-5°
Turret Rotation	360°Continuous	360°Continuous
Platform Rotation	180°	180°
Jib Movement	130°	130°

Weight		
Overall Weight	18900kg	41667lb

Power		
Diesel Engine	Deutz TD2.9 L4	Deutz TD2.9 L4
Engine Power	55.4kW 2600rpm	55.4kW 2600rpm
Diesel Tank	135L	29gal
Hydraulic Tank	165L	36gal

* The platform height plus 2m (7ft in British standard) is the working height.
Standards Compliance

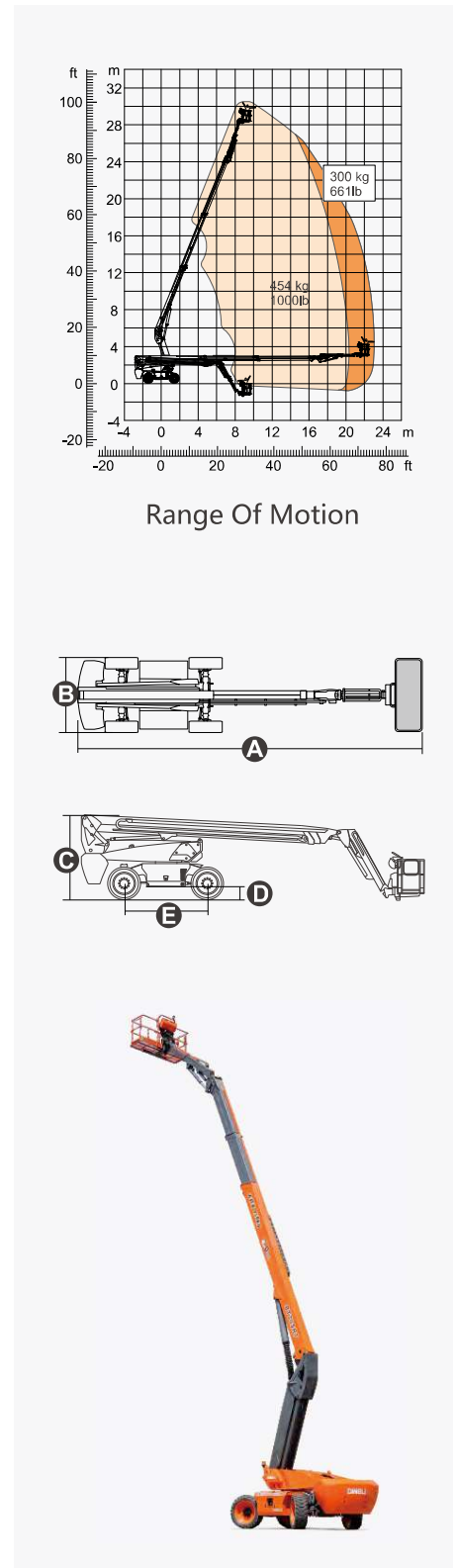

FEATURES

Standard Items

- Telescopic Jib With Maximum Reach Of 3.98m (13ft)
- Front Oscillating Axle
- Four-wheel Steering
- Four-wheel Drive
- Self-leveling Platform
- 180° Left And Right Swing Platform
- Proportional Joystick Controls
- Thumb Rocker Steer
- Drive Enable
- Ac Power Cord To Platform
- Tilt Alarm
- Descent Alarm
- Flash
- Horn
- Hour Meter
- Integral Integrated Special Drive Axle For Construction Machinery
- 360° Continuous Turntable Rotation
- Positive Traction Four Wheel Drive
- Platform Load Sense System
- Fault Diagnosis System
- Operator Anti-crushing Protection System
- Harsh Environment Kits (includes Cylinder Sleeves, Boom Dust Kits, Ground And Platform Control Box Covers)
- 12v Dc Auxiliary Power
- Deutz Td2.9 L4 55.4kw 2600rpm diesel Engine *
- Hydraulic Oil Radiator
- Anti-restart Engine Protection
- Anti-reverse Engine Device
- Auto Engine Fault Shutdown

Optional Items

Tire Options

- Rough Terrain Foam-filled **
- Rough Terrain Non-marking Foam-filled

Hydraulic Oil Options

- Hydraulic Oil No. 46 (mineral Oil) **

Additional Items

- Hydraulic Generator
- Gps Module
- Biodegradable Hydraulic Oil
- Platform Top Auxiliary Rail
- Air Line To Platform
- Welding Wire To Platform
- Work Light Package
- Aircraft Protection Package
- Protective Cover For Ac Power Plug
- Main Telescopic Boom Oil Pipe Guard
- Anti-collision Bar Installed On Working Platform
- Working Platform Outer Anti-collision Bar
- Protective Net Installed Around Working Platform
- Head Anti-collision Device Installed On Working Platform
- Engine Belt Guard
- Waterproof Rubber Pad On Engine Compartment

* Please Consult Dingli Regional Sales According To The Local Emission Standards.

** Factory Default, If You Have Other Needs, Please Inform Dingli Regional Sales.

ZHEJIANG DINGLI MACHINERY CO., LTD.

No.188 Qihang Road, Deqing, Zhejiang P.R.China 313219

Telephone +86(572)8681688

Fax +86(572)8681960

E-Mail export@cndingli.com

[Http://www.cndingli.com](http://www.cndingli.com)

