

## COMPACT 8N COMPACT 10N

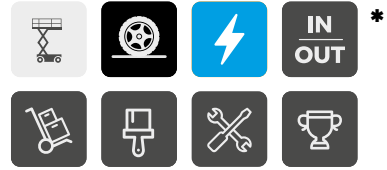

### SMART RUGGED DESIGN

- > Impact-proof counterweight with integrated ladder protection, AC motors and charger plug
- > Reinforced guardrails with additional vertical stile for maximum durability

### MAXIMIZED POTENTIAL

- > Access all worksites: foldable guardrails, lateral & longitudinal forklift pockets
- > IN/OUT usage\* with full height driving and no load restriction

### UNIQUE USER EXPERIENCE

- > Proportional movements for precise driving (AC motors)
- > Ergonomic upper control box with grab handle & speed selector

### UNBEATABLE SERVICEABILITY

- > Haulotte Activ'Energy Management for battery care
- > On-board & remote settings and diagnostic tools with Haulotte Diag, Haulotte Activ'Screen and Sherpal telematics solution

\* COMPACT 10N: indoor only

# COMPACT 8N COMPACT 10N

## ELECTRIC SCISSOR LIFTS

### TECHNICAL DATA

	COMPACT 8N AE	COMPACT 10N AE
Working height	8 m	9.8 m
Platform height	6 m	7.8 m
Max. drive working height	6 m	7.8 m
Lift capacity - inside	350 kg (2 pers.)	250 kg (2 pers.)
Lift capacity - outside	350 kg (1 pers.)	NA
Lift capacity on the extension deck	120 kg	
<b>A</b> Platform length - outside	2.4 m	
<b>B</b> Platform length - extended	3.32 m	
Length - extension	0.92 m	
<b>C</b> Platform width - outside	0.8 m	
<b>D</b> Height - stowed	2.23 m	2.35 m
Guardrails lowered	1.82 m	1.94 m
<b>E</b> Overall width	0.81 m	
<b>F</b> Length	2.5 m	
<b>G</b> Wheelbase	1.86 m	
<b>H</b> Ground clearance - center	12.5 cm	
Ground clearance - deployed potholes	2 cm	
Drive speed	0.7 / 1.5 / 4.2 km/h	
Gradeability	25 %	
Tilt (lonitudinal / lateral)	3.5° / 1.5°	
Turning radius - outside	2.05 m	
Non-marking tyres	15 x 5	
Batteries	24 V - 225 Ah (C20)	
Hydraulic system capacity	10 l	
Weight	2 120 kg	2 160 kg

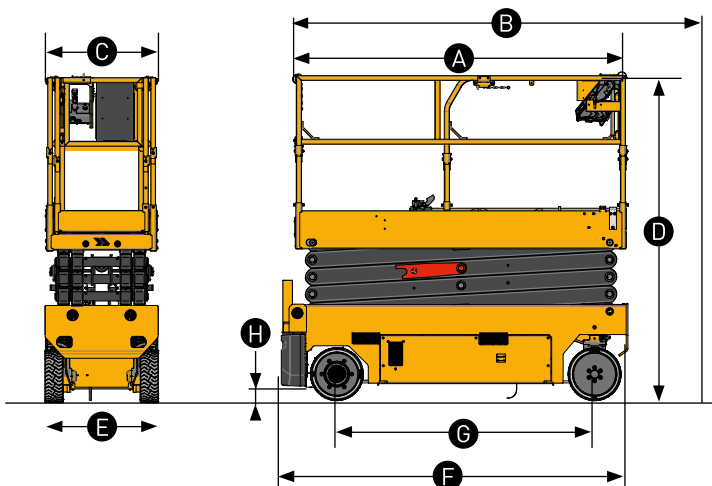

### STANDARD EQUIPMENT

- > Haulotte Activ'Energy Management: Smart CAN charger
- > 27A multivoltage charger
- > Battery access with swing out tray
- > Battery level indicator
- > Haulotte Activ'Screen (battery charge information, hourmeter, service alerts & failures in code or in text...)
- > Lateral & longitudinal forklift pockets
- > Foldable guardrails
- > Front platform extension
- > AC motors
- > Mobile upper control box
- > 2 drive speeds selector
- > Manual emergency descent
- > Mobile pothole guards
- > MyHaulotte multi-services portal access
- > 2 front steering wheels, 2 rear drive wheels
- > Solid non marking tires
- > Motion alarm
- > Electric brake release system
- > Drop bar entry

### OPTIONS AND ACCESSORIES

- > Haulotte Activ'Energy Management: automatic or manual battery water filling systems
- > AGM maintenance-free batteries
- > Secondary guarding system
- > Telematics solutions
- > Pipe cradle
- > Panel carrier
- > Swing gate entry
- > Additional protection of upper & lower control box
- > Basket plug (110 / 230 V)
- > Working light
- > Flashing light (single, dual or 360°)
- > Biodegradable hydraulic oil
- > Cold weather hydraulic oil

